

ASPEN Gully Drain Cover | Smooth

Load Class up to FACTA C250



ASPEN Stainless hardworking stainless steel products for hardwearing environments: British engineered with a lifetime guarantee.

Product Description

The Smooth Gully Drain Cover is a flat top cover, which is bead blasted and used as standard for most of the Aspen Drain Gully range.

The smooth cover can fit both round and square top Gullies.

Suitable for hygienic environments accessed by medium load factory traffic.

There are 6 other Gully Drain Cover options available in the Aspen Stainless range.

Technical Specification

- > 10mm stainless steel smooth plate.
- > 15mm x 15mm stainless steel bar
- > 25mm depth to fit all gullies.
- > Stitch welded.
- > Grade 304 stainless steel (British Standard 304S31, Euronorm 1.4301).
- > Low Slip Potential according to UKSRG in dry & wet conditions.

MODEL	REF	COVER DIMENSIONS			FACTA LOAD CLASS
		A	B	C	
SMOOTH	GC1	25	200	NA	
DURBAR	GC2	See GC2 Technical Sheet			
LADDER	GC3	See GC3 Technical Sheet			
SCALLOPED LADDER	GC4	See GC4 Technical Sheet			
LASER CUT LADDER	GC7	See GC7 Technical Sheet			
RESIN FILLED TRAY	GC5	See GC5 Technical Sheet			
LOCKING	GC6	See GC6 Technical Sheet			

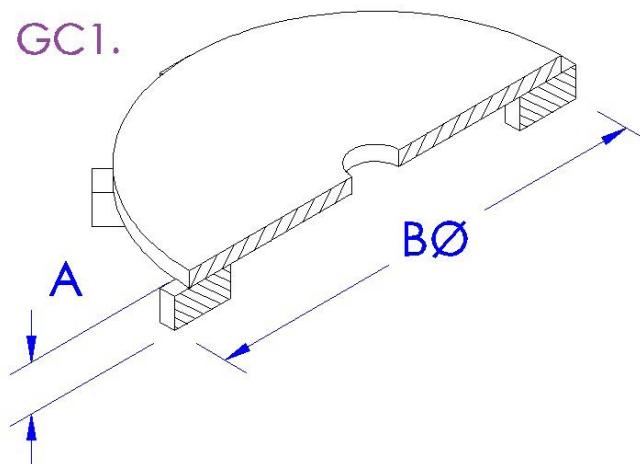

All dimensions in mm.

ASPEN Gully Drain Cover | Smooth

Load Class up to FACTA C250



ASPEN Stainless hardworking stainless steel products for hard wearing environments: British engineered with a lifetime guarantee.

ASPEN Drainage System

As a UK based designer and manufacturer, ASPEN Stainless is able to offer a full range of products to complete your drainage system including entirely bespoke drainage systems.

Maintenance

Stainless steel equipment should be occasionally thoroughly checked for retained deposits and concentrated fluid build up that causes corrosion.

Cleaning

Many factors affect the choice of cleaning method and frequency of its application. Suitable methods for stainless steel are: water and steam; mechanical non abrasive scrubbing; organic solvents and mild detergents.

ASPEN Drainage Installation

ASPEN Stainless offer supply only or full installation, with fully welded and polished joints, and commissioning. ASPEN Stainless also offer on-going annual inspection and maintenance contracts.

For advice regarding the most suitable ASPEN Stainless products for you, please contact our technical sales team today to discuss your requirements.

ASPEN Slip Resistance

Classification of slip potential surfaces in wet and dry conditions are according to 'The Assessment of Floor Slip Resistance: The UK Slip Resistance Group (UKSRG) Guidelines issues 4 / 2011'. Results are obtained from tests carried out by our trained laboratory technicians in the internal laboraboraty. All figures are measured and expressed under laboratory conditions: Actual performance may vary from the above values depending upon site conditions. Contact the Technical Sales team for the actual slip resistant values or more information about the UKSRG.

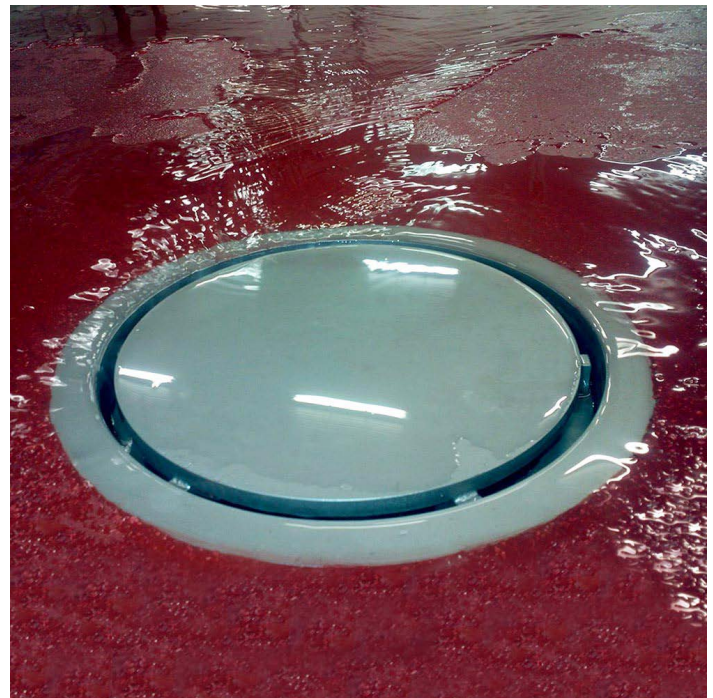

Smooth Gully Drain Cover

ASPEN Drainage Options

> Available in grade 316 stainless steel (British Standard 316S31, Euronorm 1.4401).