

ASPEN Meribel Central Outlet

Load Class up to FACTA D400



ASPEN Stainless hardworking stainless steel products for hard wearing environments: British engineered with a lifetime guarantee.

Product Description

The standard Outlet Meribel Central is the most popular Drain Channel Outlet with an adaption so the trap is fully removable rather than hinged. Rodding access under trap complete with two trash baskets.

Suitable for hygienic environments accessed by all types of factory traffic.

The standard Outlet is available in five sizes to accommodate different flow rates.

Technical Specification

- > 2mm stainless steel removable trap.
- > 2 x stainless steel removable trash basket.
- > 50mm water trap.
- > Grade 304 stainless steel (British Standard 304S31, Euronorm 1.4301).

MODEL	REF	OUTLET DIMENSIONS			FLOW RATES	FACTA LOAD CLASS
		A	B	C		
100 CHANNEL 110Ø OUTLET	OMER100110	100	110	180 INSIDE	4.0 Ltr/Sec	
100 CHANNEL 160Ø OUTLET	OMER100160	100	160	180 INSIDE	6.0 Ltr/Sec	
170 CHANNEL 110Ø OUTLET	OMER170110	170	110	180 INSIDE	4.0 Ltr/Sec	
170 CHANNEL 160Ø OUTLET	OMER170160	170	160	180 INSIDE	6.0 Ltr/Sec	
300 CHANNEL 160Ø OUTLET	OMER300160	300	160	180 INSIDE	6.0 Ltr/Sec	

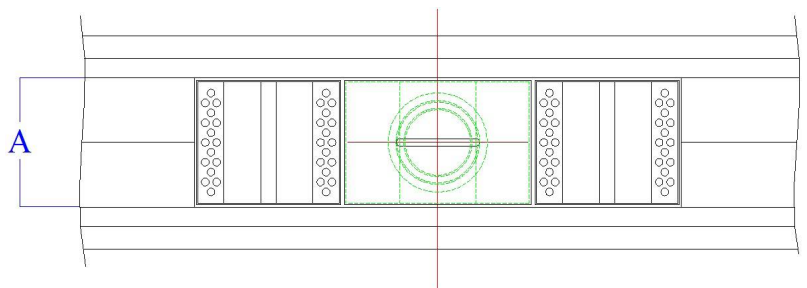
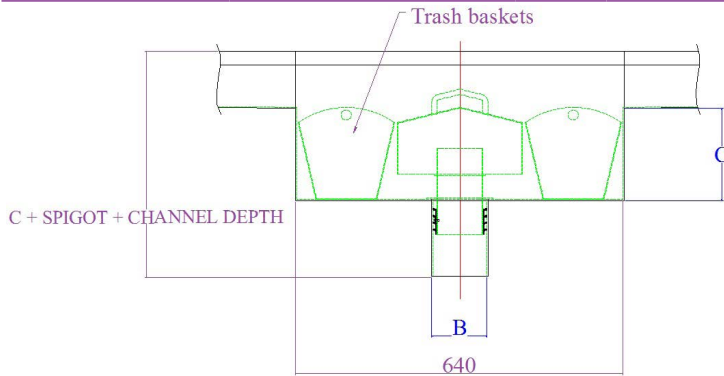

The blue measurements indicate the variable dimensions shown in the chart above. All dimensions in mm.

ASPEN Meribel Central Outlet

Load Class up to FACTA D400



ASPEN Stainless hardworking stainless steel products for hard wearing environments: British engineered with a lifetime guarantee.

ASPEN Drainage System

As a UK based designer and manufacturer, ASPEN Stainless is able to offer a full range of products to complete your drainage system including entirely bespoke drainage systems.

Key Benefits

This design retains the water to create the water trap with an option for a removable centre pipe to allow total drainage. The Meribel outlets allow rodding access and easy clean.

Maintenance

Stainless steel equipment should be occasionally thoroughly checked for retained deposits and concentrated fluid build up that causes corrosion.

Cleaning

Many factors affect the choice of cleaning method and frequency of its application. Suitable methods for stainless steel are: water and steam; mechanical non abrasive scrubbing; organic solvents and mild detergents.



Meribel Central Outlet Sample

ASPEN Drainage Installation

ASPEN Stainless offer supply only or full installation, with fully welded and polished joints, and commissioning. ASPEN Stainless also offer on-going annual inspection and maintenance contracts.

For advice regarding the most suitable ASPEN Stainless products for you, please contact our technical sales team today to discuss your requirements.

ASPEN Drainage Options

- > Available in grade 316 stainless steel (British Standard 316S31, Euronorm 1.4401).
- > Variable filtration mesh hole size.
- > Outlet Cover will dictate the load class up to D400 FACTA Loading.